

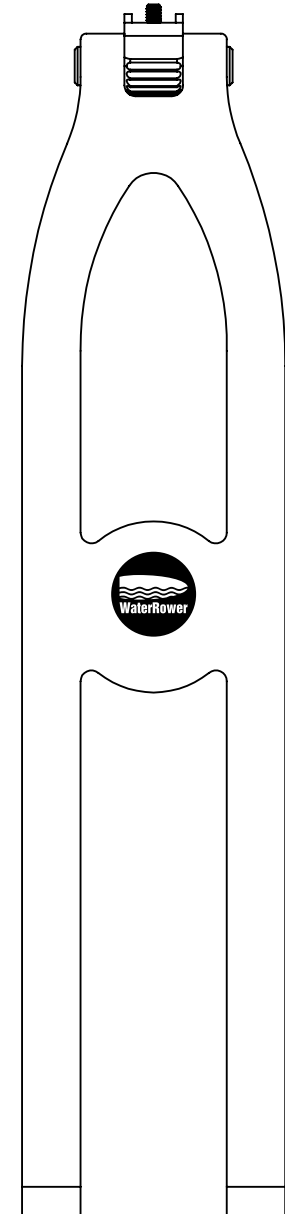

## Tablet/Phone Arm Accessory with Smart Row



### Parts

- A Tablet/Phone Arm
- B Phone Mount
- C JCB (WRB-B711) x 2
- D JCN (WRP-B700) x 4  
(D\*2 of these are preassembled on Tablet/Phone Arm)
- E 5mm Allen Key (WRP-B740) x 2 (come with rower)
- F Tie Rods (WRP-T730) (attached to rower)
- G Bracket x 2  
G† Upper Bracket

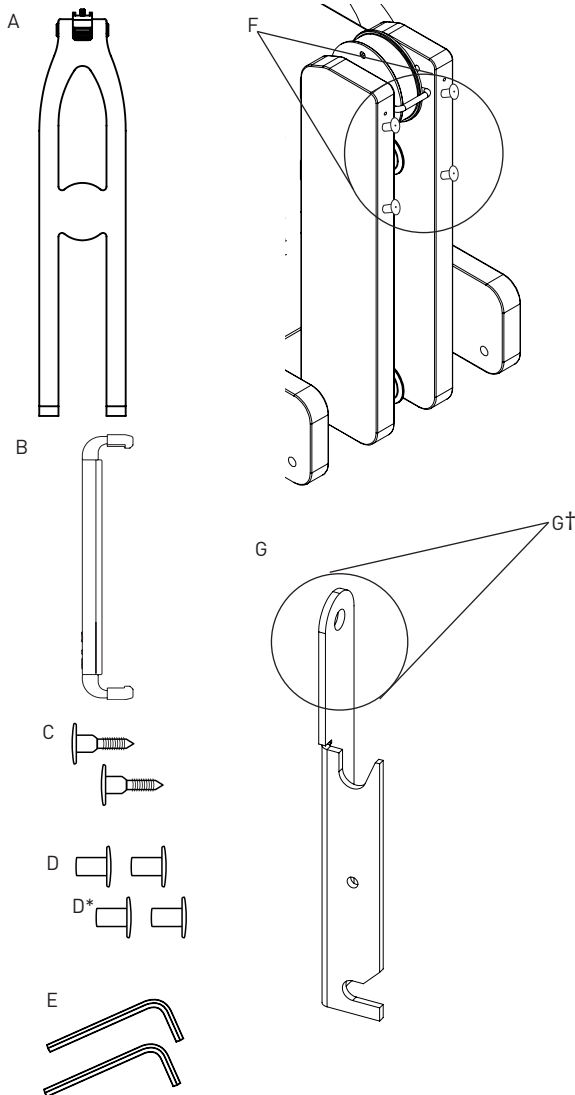

### WaterRower

WaterRower USA:  
560 Metacom Avenue, Warren, RI  
+1 (401) 247 7742  
info@waterrower.com  
www.waterrower.com

WaterRower UK:  
25 Acton Park Estate, The Vale, London W3 7QE  
+44 (0) 20 8749 8400  
info@waterrower.co.uk  
www.waterrower.co.uk

WaterRower Australia:  
72 South Street Rydalmere, NSW 2116  
+61 (0)2 9898 1405  
info@waterrower.com.au  
www.waterrower.com.au

WaterRower China:  
2F, No.3 Xiang Ming Road, Xiang An District, Xiamen 361101, China  
+86-592-5923128  
info@waterrower.com.cn  
www.waterrower.com.cn

WaterRower Germany:  
Otto-Hahn-Straße 75, 48529 Nordhorn, Germany  
+49 (0) 59 21 17 98 400  
info@waterrower.de  
www.waterrower.de

WaterRower France:  
1 rue Paul Langevin, 59200 Tourcoing, France  
+33 (0) 3 20 67 20 07  
france@waterrower.com  
www.waterrower.fr

# ASSEMBLY INSTRUCTIONS

1

Use Allen key (E) to loosen the four tie rods (F) on the forward riser, approximately three full turns.

**Do not loosen too far.**

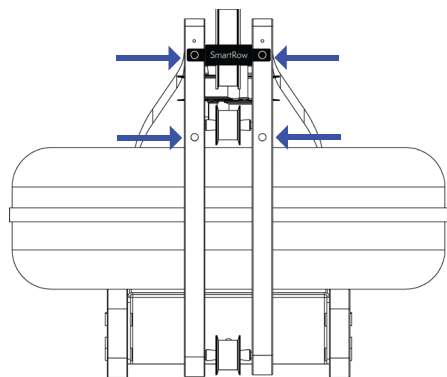

2

Slide the bracket (G) over the SmartRow Housing Cover and onto the tie rods (F); ensure the corner is aligned with the outside of the forward riser, and the upper portion of the bracket is on top. Using the Allen key (E), tighten the tie rods to secure the bracket into place.

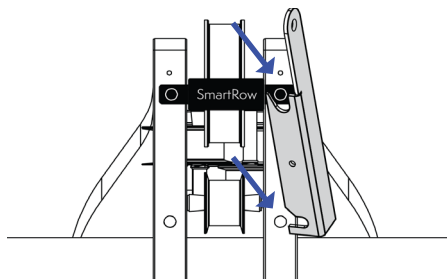

3

Repeat step 2 for other side.

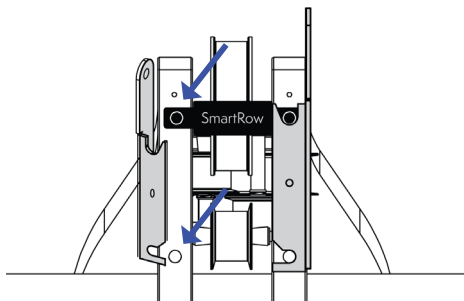

4

Lay Tablet/Phone Arm (A) flat on top of your machine; the WaterRower logo should be facing up. Align holes on the upper portion of the bracket (G†). Insert the JCB (C) to the JCN (D) on both sides and tighten to the bracket (G).

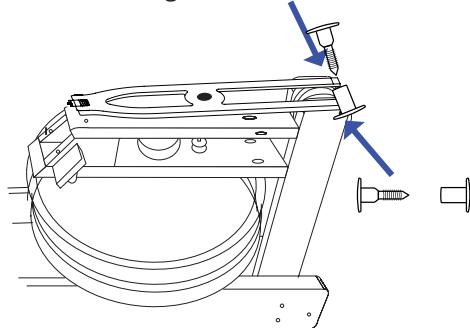

5

Using an Allen key (E) tighten JCN's (D\*) on either side of the Tablet/Phone Arm. **Repeat this step every 1-2 weeks, depending on usage.**

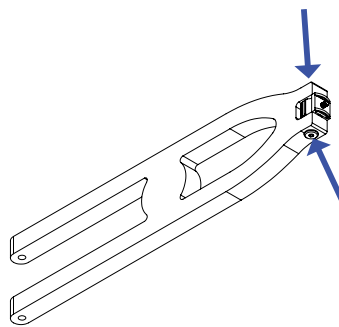

6

Screw the Tablet/Phone Mount (B) on the threaded stud.

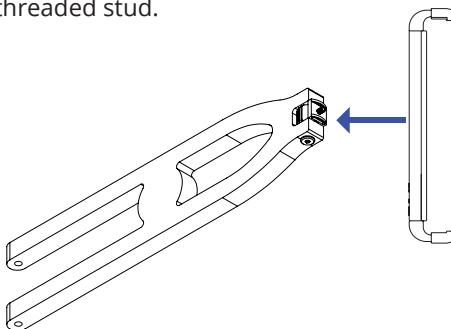

# USAGE INSTRUCTIONS

A

Pull Tablet/Phone Arm up to release kickstands for use.

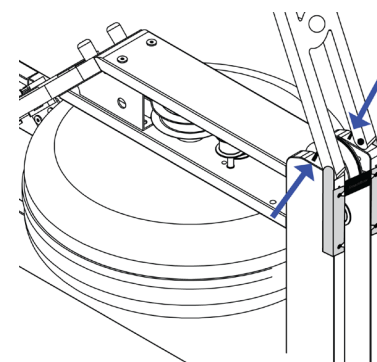

B

Lift top of Tablet/Phone Mount (B) and insert smart device into the mount.

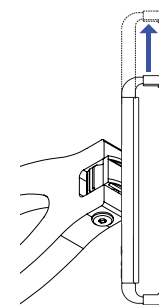

C

When finished: (1) Remove smart device, (2) lift Tablet/Phone Arm and (3) push kickstands in to return to stored position before moving WaterRower.

**Do not attempt to move or store WaterRower with Tablet/Phone Arm in usage position or with smart device attached.**

